

Heat Performance Row

PRF-ROW-TFT

Owner's Manual • Bedienungsanleitung • Le manuel du propriétaire



LifeFitness



CORPORATE HEADQUARTERS

Columbia Centre III, 9525 Bryn Mawr Avenue, Rosemont, Illinois 60018 • U.S.A.
847.288.3300 • FAX: 847.288.3703 • Service phone number: 800.351.3737 (toll-free within U.S.A., Canada)
Global Website: www.lifefitness.com

AMERICAS

North America
Life Fitness, Inc. Columbia Centre III
9525 Bryn Mawr Avenue, Rosemont, IL 60018 U.S.A.
Telephone: (847) 288 3300
Service Email: customersupport@lifefitness.com
Sales/Marketing Email: commercialsales@lifefitness.com

Brazil

Life Fitness Brasil
Av. Reboucas, 2315 Pinheiros,
Sao Paulo, SP 05401-300 BRAZIL
SAC: 0800 773 8282 option 2
Telephone: +55 (11) 3095 5200
Service Email: suportebr@lifefitness.com
Sales/Marketing Email: vendasbr@lifefitness.com

Latin America and Caribbean*

Life Fitness, Inc. Columbia Centre III
9525 Bryn Mawr Avenue Rosemont, IL 60018 U.S.A.
Telephone: (847) 288 3300
Service Email: customersupport@lifefitness.com
Sales/Marketing Email: commercialsales@lifefitness.com

EUROPE, MIDDLE EAST, and AFRICA (EMEA)

Netherlands and Luxemburg
Life Fitness Atlantic BV
Bijdorpplein 25-31, 2992 LB Barendrecht
THE NETHERLANDS
Telephone: (+31) 180 646 666
Service Email: service.benelux@lifefitness.com
Sales/Marketing Email: marketing.benelux@lifefitness.com

United Kingdom

Life Fitness UK LTD
Queen Adelaide, Ely, Cambs, CB7 4UB
Telephone: General Office (+44) 1353.666017
Customer Support (+44) 1353.665507
Service Email: uk.support@lifefitness.com
Sales/Marketing Email: life@lifefitness.com

Germany, Austria, and Switzerland

Life Fitness Europe GMBH
Neuhofweg 9, 85716 Unterschleisheim
GERMANY
Telephone:
+49 (0) 89 / 31775166 Germany
+43 (0) 1 / 6157198 Austria
+41 (0) 848 / 000901 Switzerland
Service Email: kundendienst@lifefitness.com
Sales/Marketing Email: vertrieb@lifefitness.com

Spain

Life Fitness IBERIA
C/Frederic Mompou 5,1o1a
08960 Sant Just Desvern Barcelona
SPAIN
Telephone: (+34) 93.672.4660
Service Email: servicio.tecnico@lifefitness.com
Sales/Marketing Email: info.iberia@lifefitness.com

Belgium

Life Fitness Benelux NV
Parc Industriel de Petit-Rechain, 4800 Verviers
BELGIUM
Telephone: (+32) 87 300 942
Service Email: service.benelux@lifefitness.com
Sales/Marketing Email: marketing.benelux@lifefitness.com

All Other EMEA Countries and Distributor Business EMEA*

Bijdorpplein 25-31, 2992 LB Barendrecht
THE NETHERLANDS
Telephone: (+31) 180 646 644
Service Email: EMEAServiceSupport@lifefitness.com

ASIA PACIFIC (AP)

Japan
Life Fitness Japan, Ltd
4-17-33 Minami Aoyama 1F/B1F, Minato-ku - Tokyo 107-0062
Japan
Telephone: (+81) 0120.114.482
Fax: (+81) 03-5770-5059
Service Email: service.lfj@lifefitness.com
Sales/Marketing Email: sales@lifefitnessjapan.com

Hong Kong

Life Fitness Asia Pacific LTD
32/F, Global Trade Square
21 Wong Chuk Hang Road
Hong Kong
Telephone: (+852) 2575.6262
Service Email: Service.HK@lifefitness.com
Sales/Marketing Email: hongkong.sales@lifefitness.com

All Other Asia Pacific countries and distributor business Asia Pacific*

32/F, Global Trade Square
21 Wong Chuk Hang Road
Hong Kong
Telephone: (+852) 2575.6262
Fax: (+852) 2575.6894
Service Email: Service.AP@lifefitness.com
Sales/Marketing Email: Marketing.HK.Asia@lifefitness.com

*Also check www.lifefitness.com for local representation or distributor/dealer



User and Service Documents Link

<https://www.lftechsupport.com/web/document-library/documents>

Additional information is available online using the link above.

تامول عم رفوتت | لى عة فيفاض | سببا تتر ن نل | طبارل | م ادخت . له اع ا
点击上面的链接可在线获取更多信息。

Flere oplysninger er tilgængelige online gennem linket ovenfor.

Bijkomende informatie is online beschikbaar via bovenstaande link.

Vous trouverez plus d'informations en ligne à l'aide du lien ci-dessus. ↪

Zusätzliche Informationen finden Sie online über den oben angegebenen Link.

Ulteriori informazioni sono disponibili online utilizzando il link sopra riportato.

追加情報は上記リンクを使用してオンラインで利用可能です。

상기 링크를 통해 온라인에서 추가 정보를 볼 수 있습니다.

Informacoes adicionais estao disponiveis on-line, atraves do link acima.

Дополнительная информация доступна в интернете по ссылке, указанной выше.

Mediante el enlace anterior podra acceder a informacion adicional en linea.

Ytterligere information finns online genom att använda länken ovan.

İnternet uzerinden daha fazla bilgi edinmek için yukarıdaki bağlantıyı kullanabilirsiniz.

تامول عم كانه | لى عة حاتم فيفاض | سببا تتر ن نل | طبارل | م ادخت . له اع ا

Informazio osagarria eskuragarri dago goiko estekaren bidez.

Допълнителна информация можете да намерите онлайн, като използвате връзката по-горе.

Mitjancant l'enllac anterior podreu accedir a informacio addicional en linia.

使用上面的連結線上提供額外資訊。

Dodatne informacije možete pronaći na internetu sljedeći vezu iznad.

ከላይ የተቀመጠውን አገናኝ (ሊንክ) በመጠቀም መረጃዎች አንላይን ያገኛሉ።

Lisatietoja on saatavissa verkosta kayttamalla yllä olevaa linkkia.

Wubetumi anya nsem afoforo aka ho wo websait so denam asem a ewo atifi ho a wubemia so so.

Πρόσθετες πληροφορίες είναι διαθέσιμες ονλάιν χρησιμοποιώντας το σύνδεσμο παραπάνω.

ליעל רושיקה תועצמאב טנרטניאב לבקל רשפא וסו עדימ.

Tovabbi informacio elerhető online, a fenti hivatkozás segitsegevel.

Vidbotarupplysingar eru faanlegar a netinu med tvi ad smella a tengilinn her fyrir ofan.

Plus indicium per superum situm potes invenire.

മുകളിലുള്ള ലിങ്ക് ഉപയോഗി് ഓലലതി കുടുതല് വിവരങ്ങ ലഭ്യമഗണ്.

Ytterligere informasjon er tilgjengelig på nettet via linken ovenfor.

Dodatkowe informacje są dostępne online pod powyższym odnośnikiem.

Informacoes adicionais estao disponiveis online a usar o link acima.

Informații suplimentare sunt disponibile online, utilizand link-ul de mai sus.

Dodatne informacije dostupne su na mreži putem gornjeg linka.

Ďalšie informacie su dostupne online na vyššie uvedenom odkaze.



TABLE OF CONTENTS

SAFETY	6
Safety Instructions.....	6
Disposal of	7
OVERVIEW.....	8
Performance Rower	8
Specifications	9
GETTING STARTED/ASSEMBLY/INSTALLATION/SPARE PARTS.....	11
Parts	11
Stabilizer Assembly.....	12
Positioning the Console	12
Connecting the Battery	13
Warning Label Replacement.....	14
Console Setup.....	15
Settings Menu Access	16
OPERATION.....	16
Console Overview	16
Turning the Rower ON and OFF	17
Workout Screen Overview	17
Training Mode Tiles (displayed in information overview).....	18
Splits	19
Pause Mode	20
Chest Belts.....	20
Phone Holder	21
Handle Buttons.....	21
Empty Handle Battery	21
Handle Battery Replacement.....	21
Test New Handle Battery.....	23
Binding/Footplate.....	24
Resistance Knob.....	24
How to Row.....	25
After Your Workout.	25
Moving the Rower.....	25
MAINTENANCE/SERVICE SCHEDULES.....	26
WARRANTY	28
What is Covered	28
Who is Covered	28
How long it is covered	28
Who Pays Transportation and Insurance for Service	28

What We Will Do To Correct Covered Defects 28
What is Not Covered 28
What You Must Do 28
How to Get Parts and Service 28
Exclusive Warranty 28
Changes in Warranty Not Authorized 29
Effects of State Laws 29
Our Pledge To You 29
Warranty Information..... 29

SAFETY

Safety Instructions

WARNING: To reduce the risk of serious injury due to improper use of the training equipment, carefully read and adhere to the following important precautions and information before operating the rower.

WARNING: Heart rate monitoring systems may be inaccurate. Over exercising may result in serious injury or death. If you feel faint, stop exercising immediately.

- It is the responsibility of the owner to ensure that all users are informed of all warnings and precautions for proper use of the training equipment and it is only authorized for use in a supervised environment with qualified instructors.
- Do not operate the training equipment until it has been properly assembled and inspected as described in this manual.
- Keep the training equipment away from moisture and dust. Do not place the training equipment in a garage, covered patio, near water or pools. Operating temperature of the training equipment must be between 15°C~40°C Celsius (59°~104°F) at max. humidity of 65%.
- The training equipment must be on a stable, leveled base and installed in the horizontal position. If the training equipment is to be placed on a hardwood floor or carpet, it is recommended to place a floor mat beneath the rower, to protect the floor from becoming damaged.
- The level of safety of the training equipment can only be guaranteed if it is regularly checked for possible damage as well as wear and tear (e.g. fixing points, toe straps, etc.). Consult an authorized service provider or the manufacturer to ensure the regular inspections are properly carried out.
- Carry out all maintenance, care and service procedures as described in this manual on a regular basis. Defective parts must be replaced immediately, and the device must not be used until the repairs have been carried out. Only use original parts from the manufacturer. Repairs must only be carried out by manufacturer authorized service technicians.
- Unsupervised children should always be kept away from the training device.
- If any of the adjustment devices are left projecting, they could interfere with the user's movement.

WARNING: The training equipment can be used by children aged from 14 years and above and persons with lack of experience and knowledge if they have been given supervision or instruction concerning use of the appliance in a safe way and understand the hazards involved. Persons with reduced physical, sensory or mental capabilities are prohibited from using the training equipment. Children shall not play with the training equipment. Cleaning and user maintenance shall not be made by children without supervision.

- The training equipment must not be used by persons exceeding weight of 330 lbs./150 kg.
- Always wear appropriate tight-fitting athletic attire and shoes.
- If you feel pain or dizziness while exercising, stop immediately. It is recommended that you consult a doctor if the pain does not subside for an extended period.
- All data shown on the display, especially the Watt values generated by the integrated power sensor serve merely as information and to help guide training. Only exercise within your physical limitations.
- Place the handle in its fixture after each workout.

WARNING: All data shown on the display serves merely as information to help guide training and may not be correct. Only exercise within your physical limitations.

WARNING: If you have pre-existing health problems or a disability, it is recommended that you consult your physician, in order to find the training method which is best suited to you. Incorrect or extensive training can result in serious health injuries. The manufacturer expressly assumes no responsibility for health risks, personal injury, property damage or consequential damages sustained by or through the use of this device, unless it is a case of consequential damage which can be traced back to faulty material and/or manufacturing, and which come under the responsibility of the manufacturer.

WARNING: Do not position or store the rower vertically.

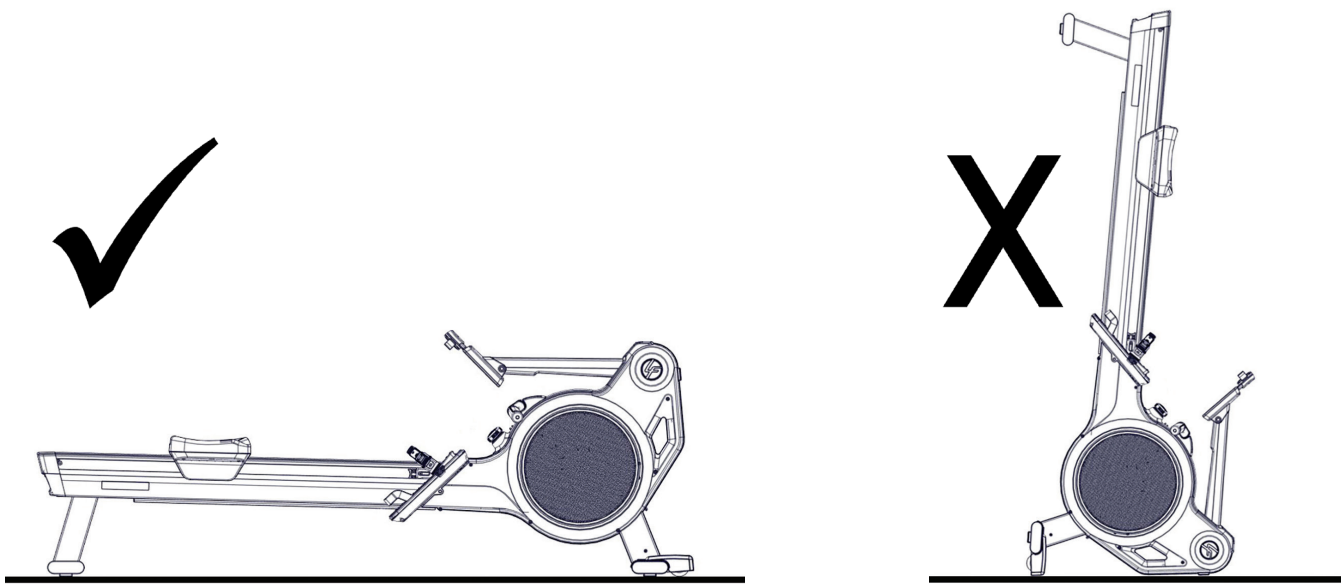

WARNING: Danger of injury! Do not touch any moving parts such as the flywheel, chain or sprocket during operation.

WARNING: Do not reach inside the shroud and touch the sprocket or chain.

WARNING: Read all precautions and instructions in this manual before you start using this equipment. Please keep this manual for future reference. Improper assembly, use or maintenance can void the warranty terms.

WARNING: The LIPO battery inside the shroud may only be changed by certified Life Fitness service technicians.

WARNING: Batteries may not be exploited to fire or get into contact with other metal objects. If you don't use the equipment for a longer period of time, please remove the batteries to avoid any damage by leaking or corroding batteries. If the battery is depleted, insert new batteries into the handle. If the battery has leaked, remove all residue immediately. Avoid contact with eyes and if you come in contact with residue, wash thoroughly.

Disposal of Product and Batteries

Products or batteries labelled with this symbol may not be disposed of with normal household refuse. For proper disposal, please find out about the applicable laws or guidelines on disposing of electrical devices and batteries in your local area and adhere to them.

Signed products or batteries with this symbol may not be disposed of in normal domestic refuse. Please familiarize yourself with relevant local laws or guidelines for the disposal of electrical devices and batteries and act accordingly. Before disposing of the handle, please remove the batteries. Products or batteries labelled with this symbol may not be disposed of along with normal household refuse. For proper disposal, please find out about the applicable laws or guidelines on disposing of electrical devices and batteries in your local area and adhere to them.



OVERVIEW

Performance Rower

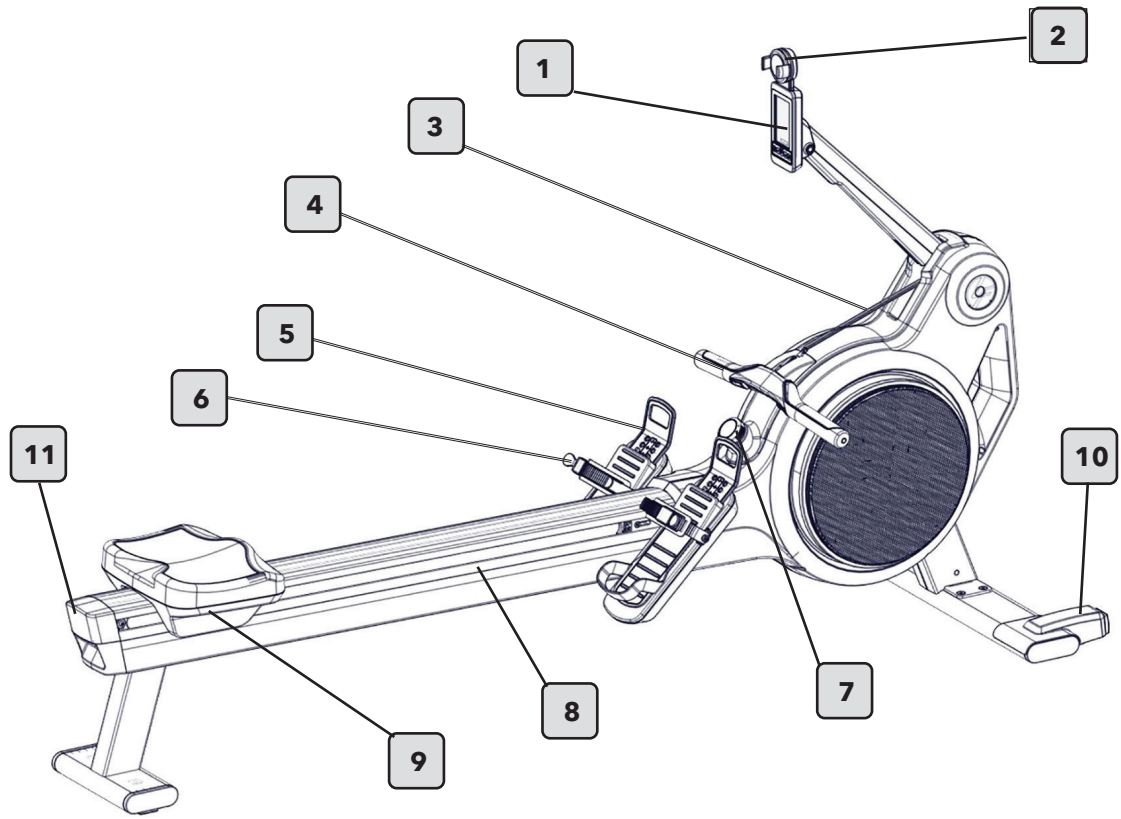

ITEM	DESCRIPTION
1	Rower console
2	Phone holder
3	Chain
4	Handle with remote buttons
5	Foot length adjustment
6	Quick release footstrap binding
7	Resistance adjustment knob
8	Rail
9	Seat
10	Transport wheels
11	Transport handle

Specifications

The Performance Rower is not suitable for therapeutic purposes

Specifications	EN ISO 20957-1 / EN 957-7 / prEN ISO 20975-7, Product Class SB, adjustment by repeatable resistance steps
Braking System	Speed Independent
Product Gross Weight	Approx. 62kg
Max User Weight	330 lb (150 kg)
Bluetooth LE 4.2	0 dBm 1 mW / max. +4 dBm 2,402 GHz und 2,480 GHz
WIFI	IEEE 802.11b,g,n,d,e,i compliant Frequency: 2,340-2,390 GHz Transmission Power: 12,5 - 20dBm
ANT	2,400 GHz - 2,524 GHz
Handle Battery	2032 Coin Battery
Length / Width / Height	84" x 31.88" x 48.03" (213 x 81 x 122 cm)
Surface Area	18.6ft ² (1.73m ²)

EU Declaration of Conformity

Electronic components satisfy the EMC Directive 2014/53/EU, EMC Directive 99/519/EC, and EN 60335-1:2012/ A14:2019 for electrical safety.

The Declaration of Conformity can be viewed at www.lifefitness.com



FCC Compliance

This device complies with part 15 of the FCC rules. Operation is subject to the following two conditions: (1) This device may not cause harmful interference, and (2) this device must accept any interference received, including interference that may cause undesired operation.

Note: This equipment has been tested and found to comply with the limits for a Class B digital device, pursuant to part 15 of the FCC Rules. These limits are designed to provide reasonable protection against harmful interference in a residential installation. This equipment generates, uses, and can radiate radio frequency energy and, if not installed and used in accordance with the instructions, may cause harmful interference to radio communications. However, there is no guarantee that interference will not occur in a particular installation. If this equipment does cause harmful interference to radio or television reception, which can be determined by turning the equipment off and on, the user is encouraged to try to correct the interference by one or more of the following measures: • Reorient or relocate the receiving antenna. • Increase the separation between the equipment and receiver. • Connect the equipment to an outlet on a circuit different from that to which the receiver is connected. • Consult the dealer or an experienced radio/TV technician for help. Important: Changes or modifications to this product not authorized by Indoor Cycling Group could void the electromagnetic compatibility (EMC) and wireless compliance and negate your authority to operate the product. This product has demonstrated EMC compliance under conditions that included the use of compliant peripheral devices and shielded cables between system components. It is important that you use compliant peripheral devices and shielded cables between system components to reduce the possibility of causing interference to radios, televisions, and other electronic devices.

Canadian regulatory statement This device complies with Industry Canada licence-exempt RSS standard(s). Operation is subject to the following two conditions: (1) this device may not cause interference, and (2) this device must accept any interference, including interference that may cause undesired operation of the device.

Le présent appareil est conforme aux CNR d'Industrie Canada applicables aux appareils radio exempts de licence. L'exploitation est autorisée aux deux conditions suivantes : (1) l'appareil ne doit pas produire de brouillage, et (2) l'utilisateur de l'appareil doit accepter tout brouillage radioélectrique subi, même si le brouillage est susceptible d'en compromettre le fonctionnement.

Training Area

Allow a minimum safety distance to any nearby equipment, objects or walls as illustrated below.

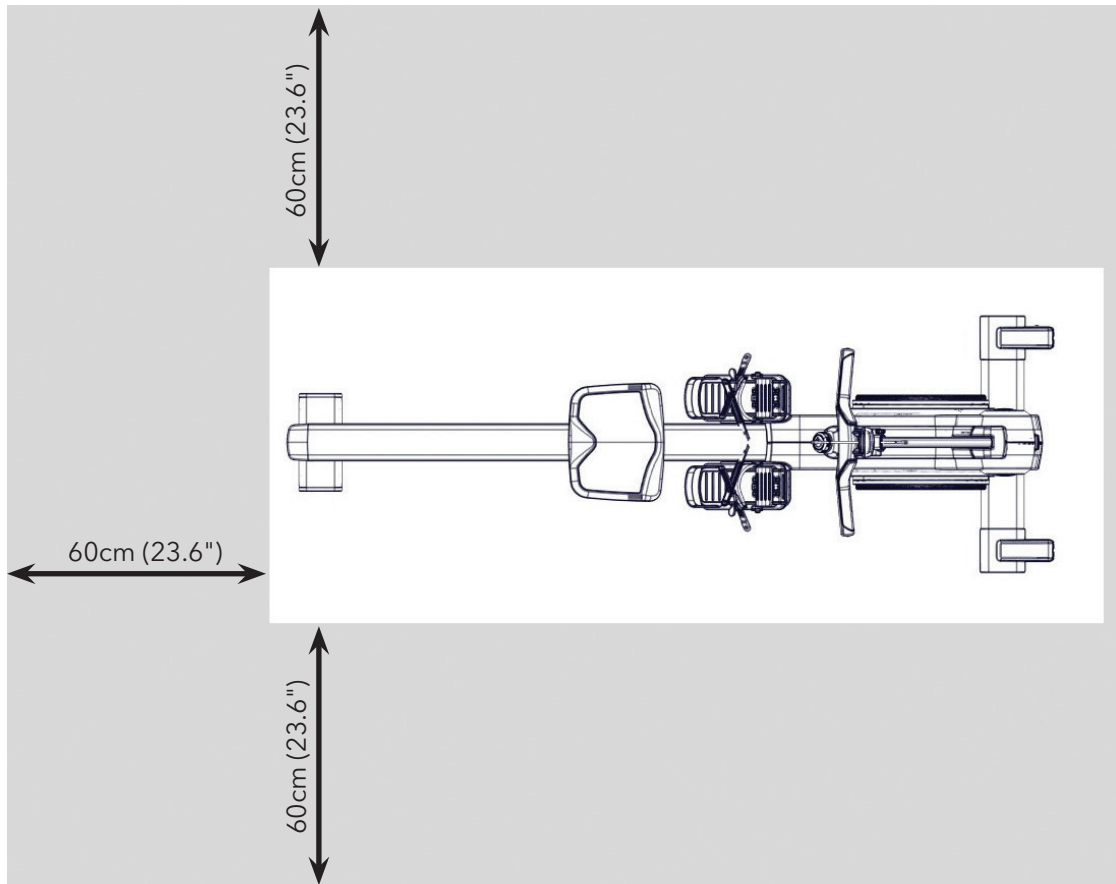

GETTING STARTED/ASSEMBLY/INSTALLATION/SPARE PARTS

Parts

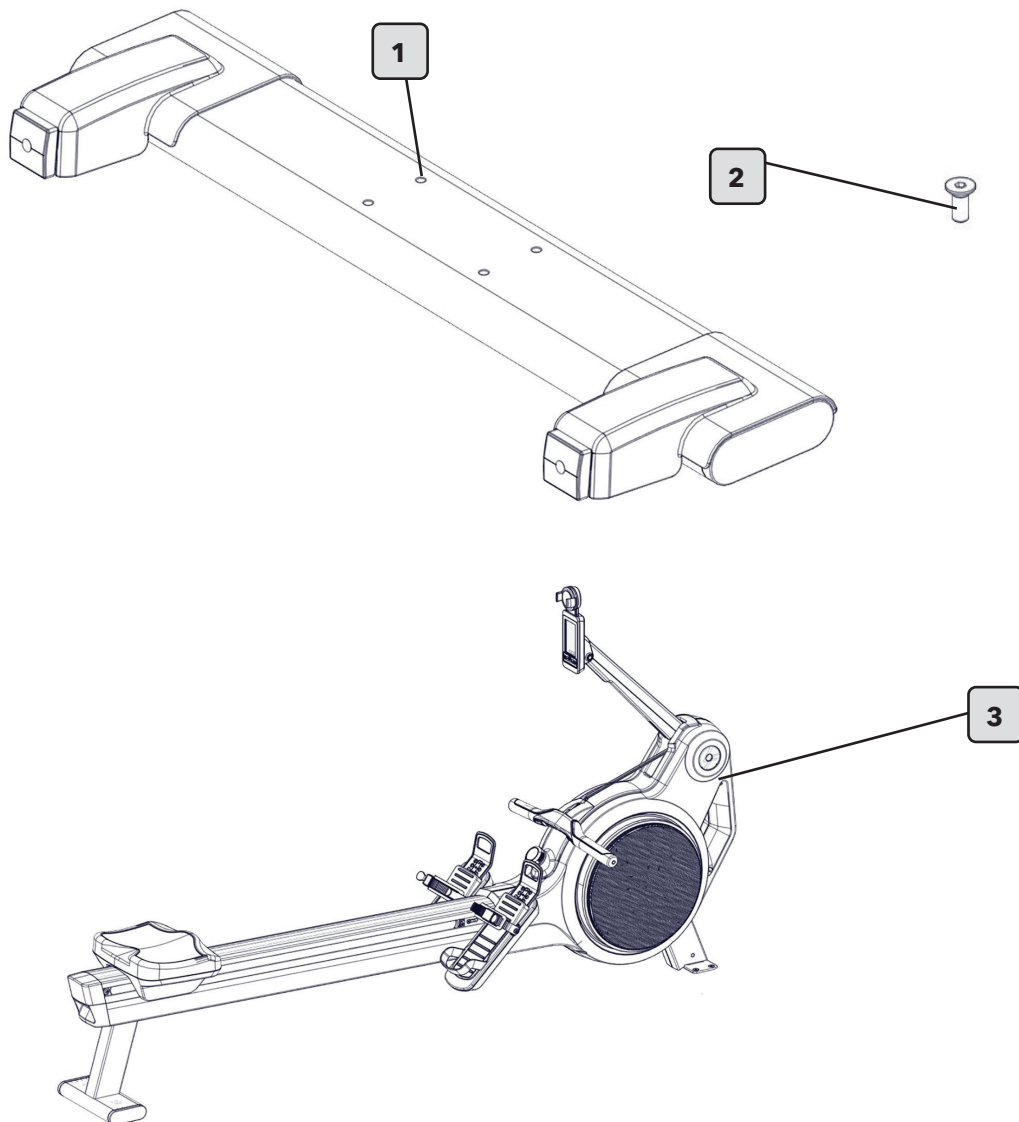

ITEM	QTY	SPAR PART NUMBER	DESCRIPTION
1	1	140-01-00014-01	Stabilizer
2	1	(includes stabilizer and 4 bolts)	Bolts
3	1	Not available as spare part	Rower

REQUIRED TOOLS FOR ASSEMBLY

Torque wrench

6 mm standard hex bit socket driver

Phillips head screwdriver (No. 1)

Stabilizer Assembly

Stabilizer Assembly

1.

ITEM	QTY
1	1
2	4

100% 

37 FT-LBS (50 Nm)

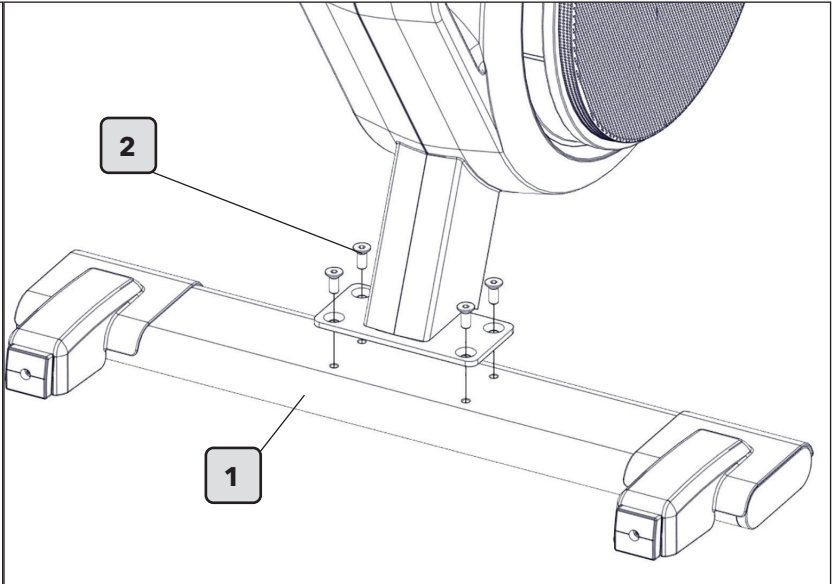

Positioning the Console

2.
2.1 Raise the arm and snap into position

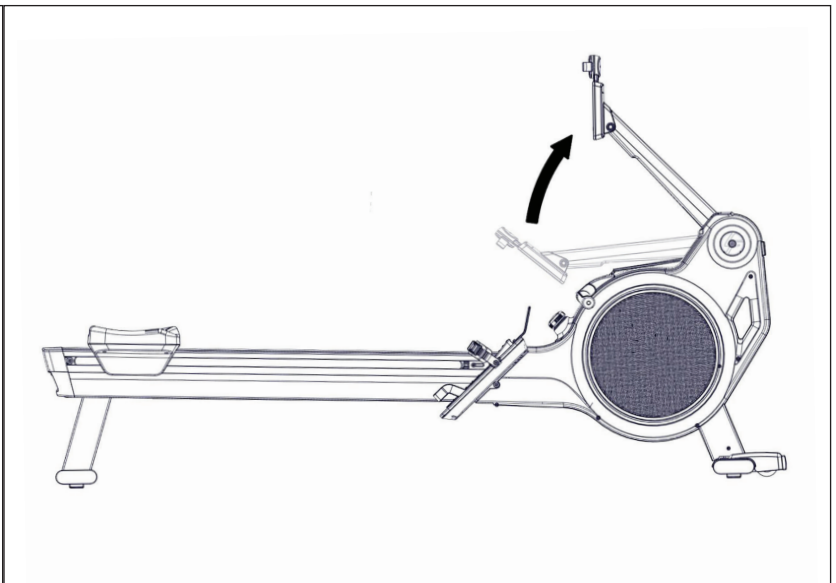

Connecting the Battery

3.

1. Remove screw from the cover
2. Turn the cover clockwise
3. Pull the cover away from the rower

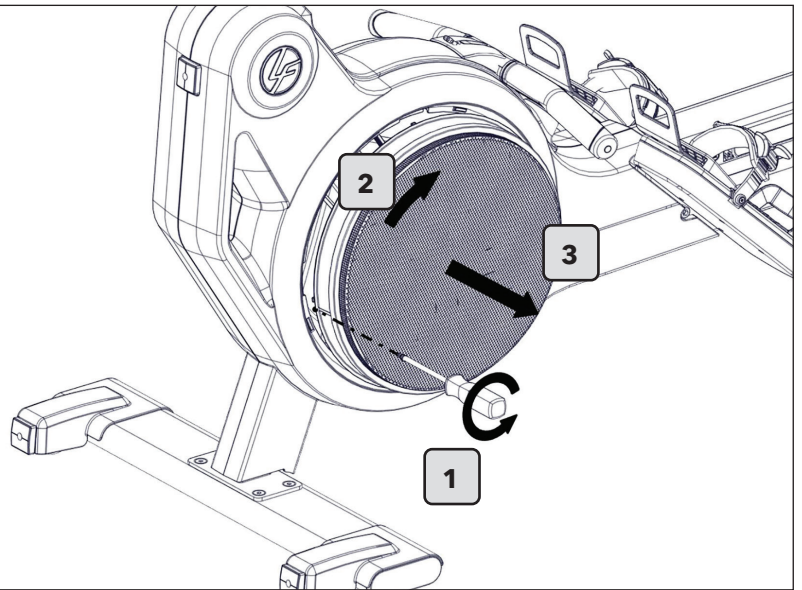

4.

1. Plug in the connectors marked "LIPO"

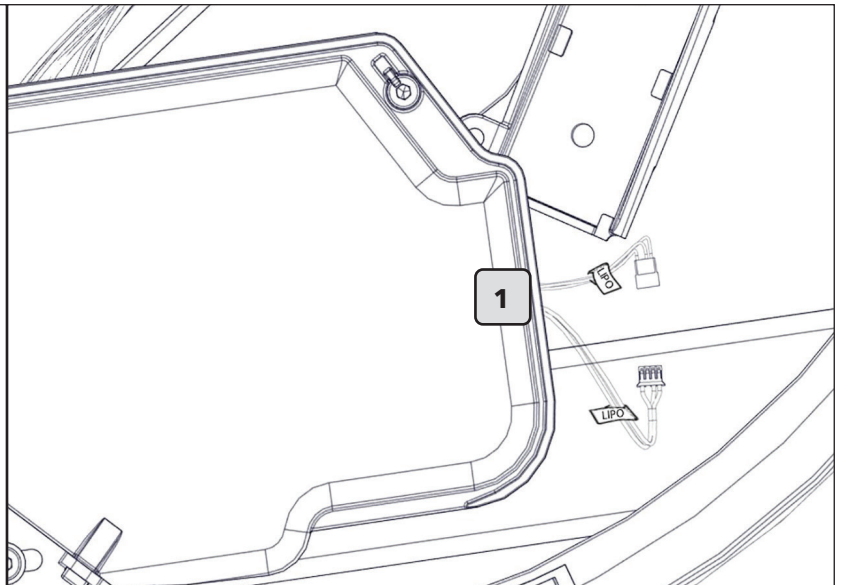

5.

1. Note the groove on the cover. It must be on the left side of the cover and aligned with the recess for the screw.
2. Position the cover on the shroud
3. Turn counter clockwise to lock

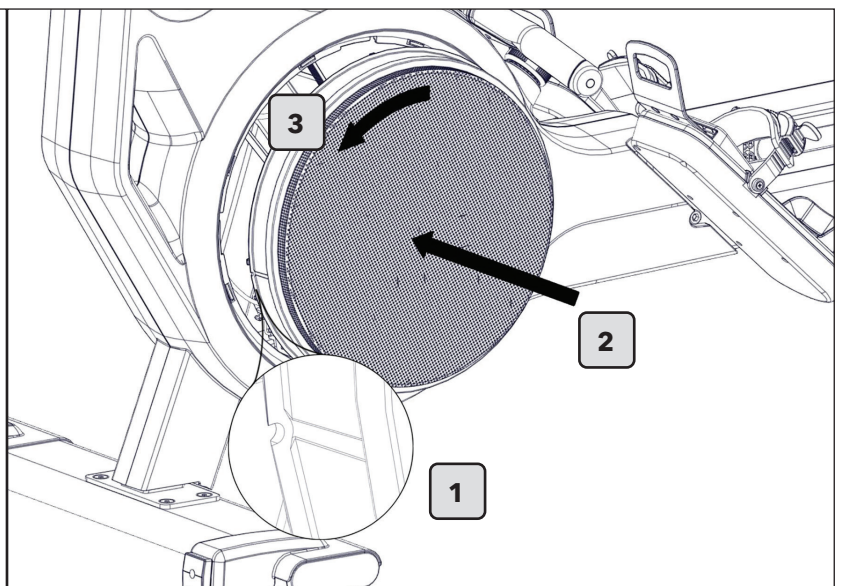

6.

1. Fasten screw

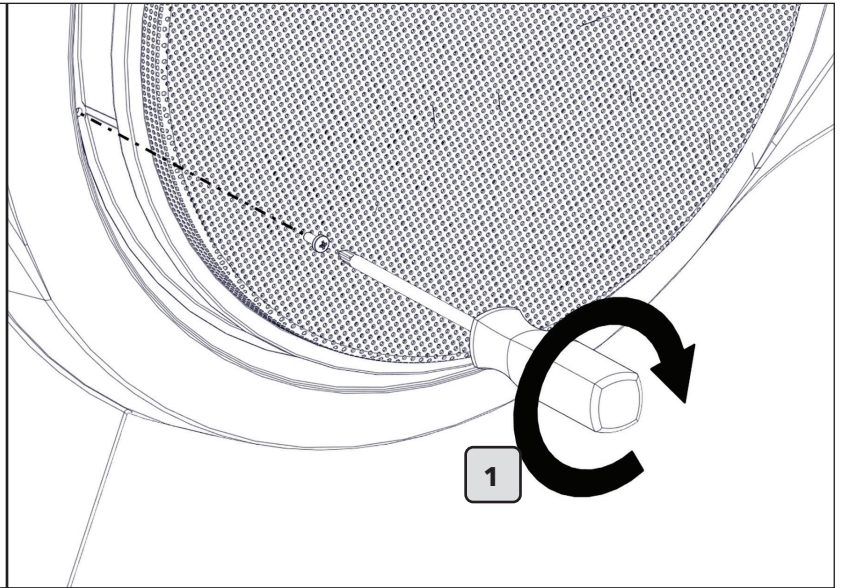

Warning Label Replacement

7.

1. Replace the warning label with a label in your local language which can be found inside the box.

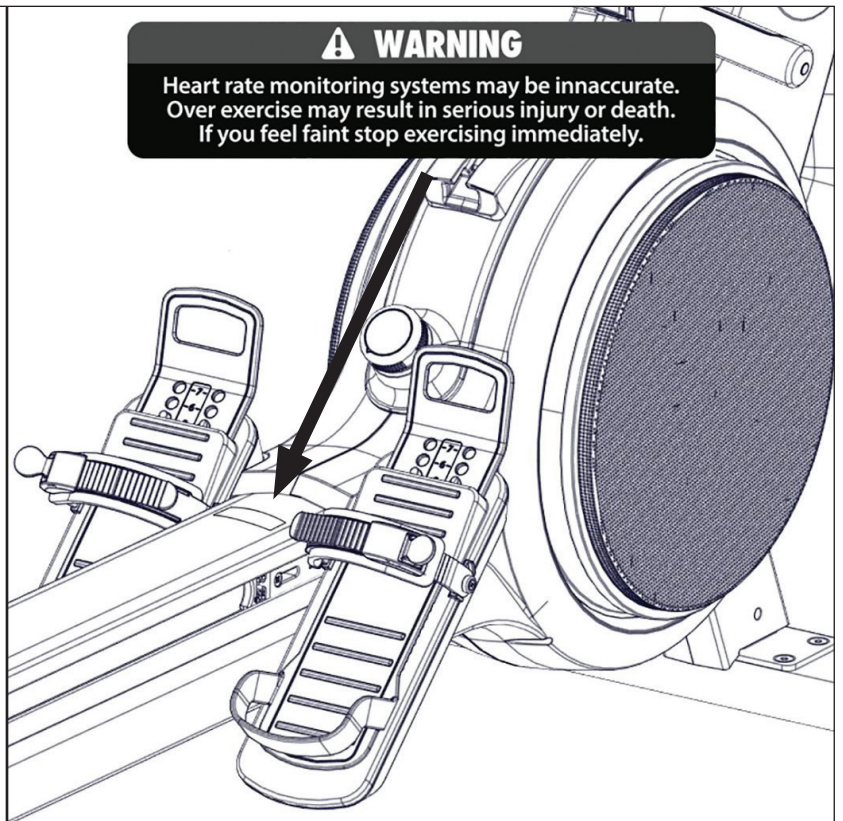

Console Setup

The console will automatically turn on within approx. 20 seconds after the handle is pulled once. The console will prompt and guide you through the setup procedure when the rower is started for the first time. These settings can be changed at a later point in time in the settings menu.

LANGUAGE: Selection Menu

WEIGHT UNITS: KG / LBS

SELECTING COLOR MODE:

Enables the user to view the power or heart rate training Coach by Color screen in either of 3 ways

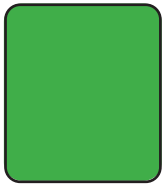

FULL SCREEN

Full Screen
- Training
Zone Color
is displayed
over the entire
screen



BANNER

Training
Zone Color is
displayed as
a small bar at
the top of the
screen

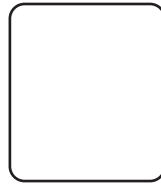

OFF

Training
Zone Color
is NOT
displayed

FRONT LED: ON/OFF

Default: OFF. By turning the light on, the trainer receives color indication via the front LED during a Coach By Color course. The background lighting of the display remains unaffected by this setting.

ROWER ID

During installation each must be given its own unique identification number. The identification number is required for use with ICG Connect and App pairing. Hold the arrow button to quickly increase/decrease value in increments of 5.

Settings Menu Access

Advanced settings can be made in the settings menu. To access a specific button combination must be pushed.

ENTERING SETTINGS MENU

When in the mode selection screen, press the DOWN ARROW and the SPLIT BUTTON simultaneously for 3 seconds to enter the settings menu.

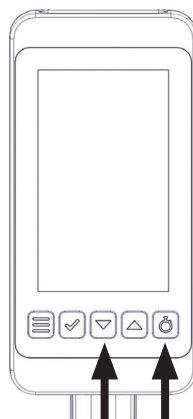

OPERATION

Console Overview

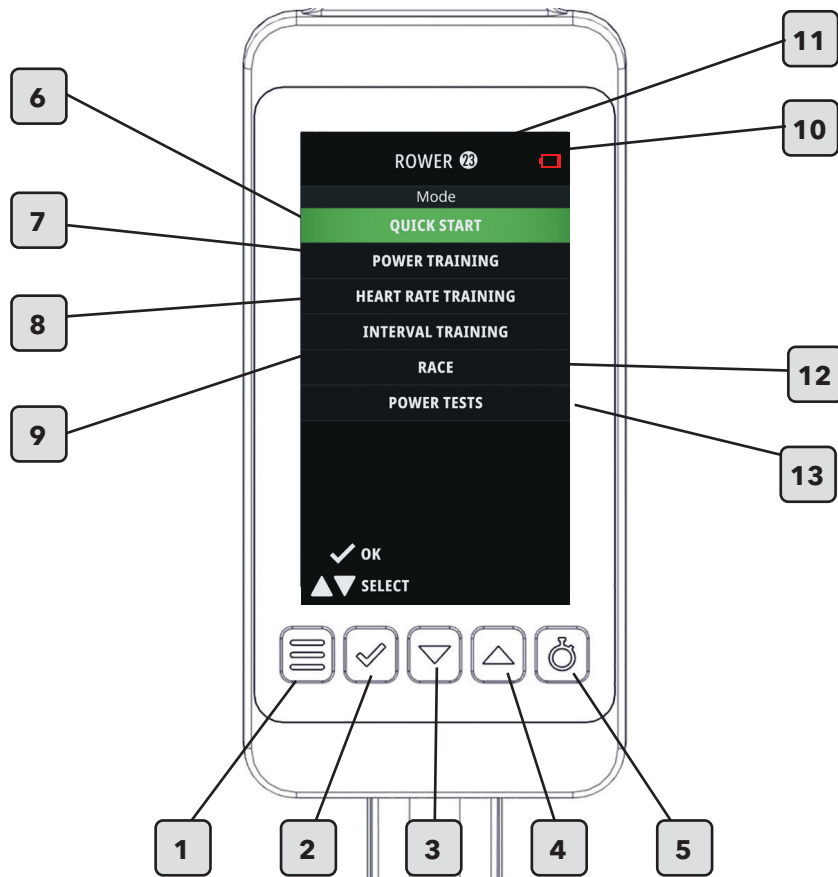

ITEM	DATA READOUTS/BUTTONS	DESCRIPTION
1	Menu / Back Button.	Menu / Back button.
2	Check Mark	Confirmation button.
3	Down Arrow	Push to move cursor down in the menus.
4	Up Arrow	Push to move cursor up in the menus.
5	Split Button	Push to start a split. Once started, a split will count the distance rowed until the split button is pressed again.
6	Quick Start	The Quick Start mode allows training without entering additional data.
7	Power Training	The Power Training mode enables you to enter additional user settings and to connect the computer to a compatible chest harness. In this mode, the individual threshold (RacePace/FTP and max HR) can be precisely entered, or if not known, calculated based on the biometric data entered into the console. The Power Training mode also utilizes Coach By Color training guidance based on power or heart rate.
8	Heart Rate Training	The Heart Rate Training mode enables you to enter additional user settings and to connect the computer to a compatible chest strap. In this mode, the individual threshold (RacePace/FTP and max HR) can be precisely entered, or if not known, calculated based on the biometric data entered into the console. The Heart Rate Training mode also utilizes Coach By Color training guidance based on power or heart rate.
9	Interval Training	Training mode in which a personalized interval training can be defined. Target distance / time, number of sets and rest period between sets can be defined according to your preferences for your workout.
10	Battery Icon	When flashing, the battery charge is low but the rower can still be used normally. The rower must be used for approx. 15 min until the icon is no longer visible.

11	Rower ID	Rower Identification number.
12	Race	The Race mode gives you the option to select a distance, pace and race against a boat displayed on the console. The "Race a Friend" mode allows you to have a live race with an adjacent rower.
13	Power Tests	The RacePace/FTP (power) test makes it possible to determine a user's individual FTP value in an evaluation

Turning the Rower ON and OFF

Turn on the rower by pulling the handle of the rower for one complete stroke. The rower will automatically shut off when no longer in use.

Workout Screen Overview

The workout screens consist of 4 - 8 multiple tiles or power curve which provide various metrics during your workout.

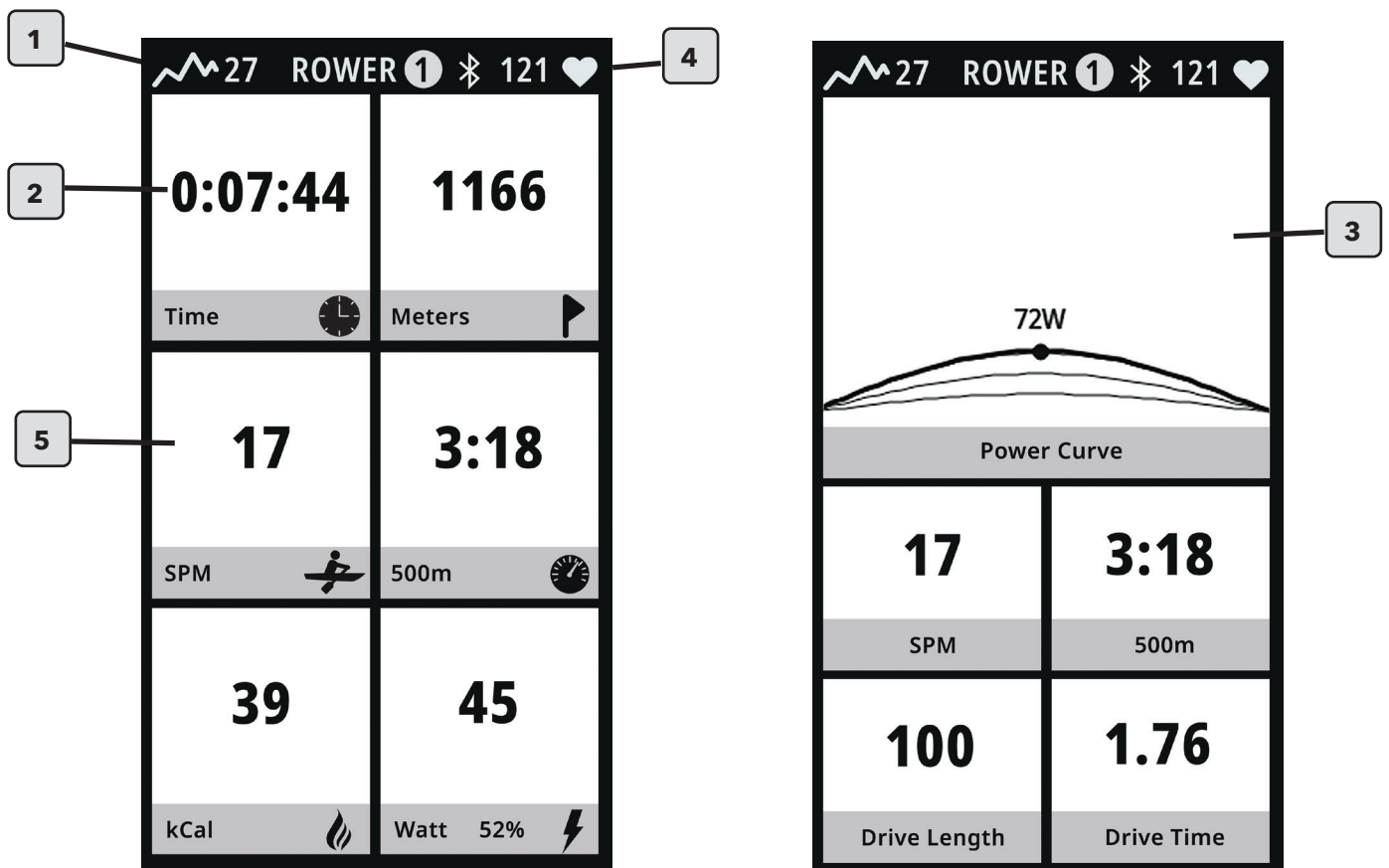

ITEM	DATA	DESCRIPTION
1	Resistance level	The value indicates the position of the resistance knob 0 - 100.
2	Workout time	Indicates the accumulated workout time
3	Power Graph	Graph which depicts the stroke length and at which point the maximum power was achieved. The last 5 strokes will also be depicted on the graph.
4	Heart Rate	The value indicates the current BPM
5	Tile	Tiles provide specific metrics. See page 17 for an overview of the available metrics.

Training Mode Tiles (displayed in information overview)

TILE NAME	DESCRIPTION	QUICK START	POWER TRAINING	HEART RATE TRAINING	INTERVAL	RACE	TESTS
SPM	Strokes per Minute	X	X	X	X		X
500m	Current 500m pace	X	X	X	X	X	X
Watt	Current Power	X	X	X	X		X
kCal	Calorie Consumption	X	X	X	X	(X)	
Meters	Distance Rowed	X	X	X	X	X	
BPM	Heart Rate (beats per minute)	X	X	X	X	X	X
Split	Current split time/distance	X	X	X			
Last Split	Last split time/distance	X	X	X			
500m Avg	Average pace required to row 500m	X	X	X	(X)	(X)	X
500m Max	Best pace in current workout	(X)	(X)	(X)			
Watt Avg	Average Power	(X)	X	(X)	(X)	(X)	X
Watt Max	Maximum Power	(X)	(X)	(X)			
SPM Avg	Average Strokes Per Minute	X	X	X	(X)	(X)	X
SPM Max	Maximum Strokes Per Minute	(X)	(X)	(X)			
BPM Avg	Average Beats Per Minute	X	(X)	X	(X)	(X)	
BPM Max	Maximum Beats Per Minute	(X)	(X)	(X)			
Power Graph	Displayed power Rower	X	X	X			
Drive Length	Current Drive Length	X	X	X			
Drive Time	Duration of one drive	X	X	X			
CBC	Coach by Color		X	X		*	
Zone	Current Coach by Color Zone		(X)	(X)		*	
TSS/IF	Current Training Stress Score/Intensity factor		(X)	(X)			
Watt/KG	Power / Weight Ratio		(X)	(X)			
Watt/HR	Power / Heart Rate Ratio		(X)	(X)			
Level		X	X	X	X	X	X
Interval	Current interval				X		

X	Available during workout only
*	Available only if FTP is entered to the console before starting your workout.
(X)	Shown in the workout summary

Splits

A split can be started by pushing the split button on the handle (fig. 1) or the console (fig. 2). When started, 2 new tiles will appear recording the time and distance. The current split (fig. 3) and last split (fig. 4) will be displayed on the screen but multiple splits can be completed in each workout. After your workout, the results of all the splits can be reviewed after pushing the menu button and then Splits (fig. 5).

Handle button

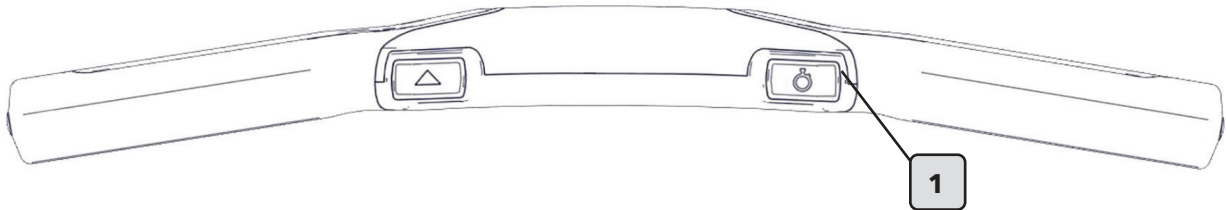

Console button

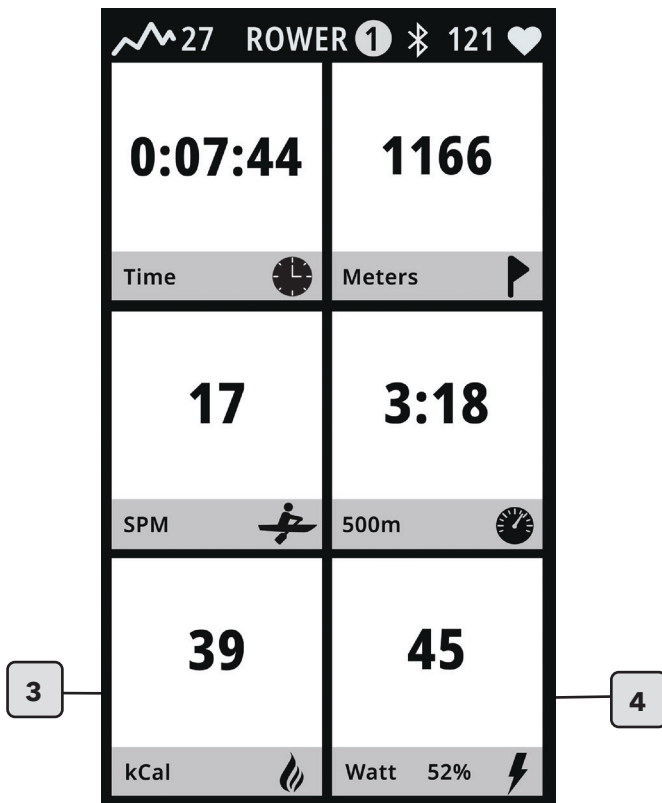
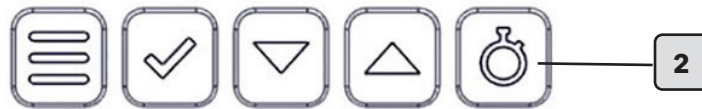

Pause Mode

You can briefly stop and continue your training without losing your workout data by entering the pause mode. There are two different methods in which the pause mode can be activated

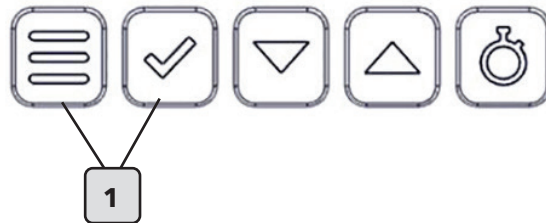

- 1.** Push the check mark or menu button during your workout to pause your workout. Push the check mark button again to continue.
- 2.** Stop rowing and once the flywheel has stopped, the pause mode will be activated. Your workout can be resumed by rowing but if adjustments were made to the console during the pause resume your training by pushing the tick button.

Summary

When selected, an overview of the stats from your training session are displayed.

Adjust FTP

Allow adjustment of Race Pace/FTP without ending the training session. Only available in Power Training, Heart Rate Training and Race modes.

Splits

View all lap distances and times from current workout

HR Connection

Connect / disconnect to Heart Rate Chest belt.

Restart Workout

Begins a new workout with the entered user settings.

End Workout

Ends workout ,resets user settings and deletes user data.

Chest Belts

CHEST BELTS	
BLE compatible heart rate sensors	ANT+ compatible heart rate monitors.

Phone Holder

Phone Holder (fig. a).

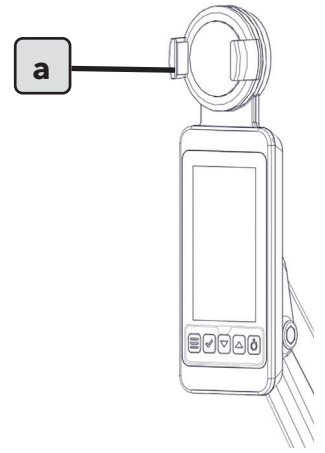

Warning:

Do not use the phone holder if your device is slippery or wet.
Use only if your device fits securely in the mobile phone holder.

Maximum dimensions and weight:
6.7x3.1x0.4 Inches (170x80x12mm) Weight: 8.1 ounces (230gr.)

Minimum dimensions
2.2x2.8x0.2 Inches (55x70x6mm)

Handle Buttons

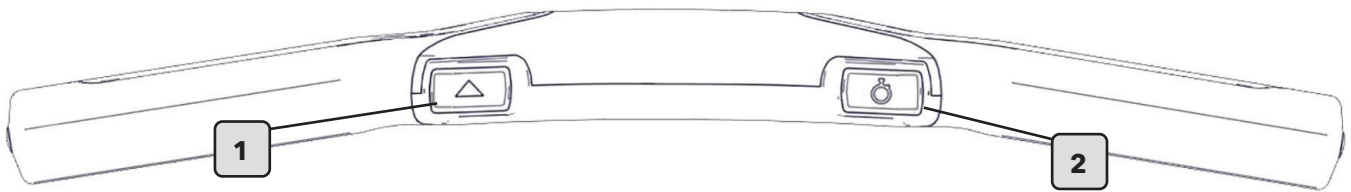

ITEM	DATA READOUTS/BUTTONS	DESCRIPTION
1	Up Arrow	Toggle through console screens
2	Split	Start and stop splits

Empty Handle Battery

If the handle battery is low, the user will be notified that the battery level is critical and that the staff should be notified. If you confirm with ok, the rower and handle will still function during the duration of the workout. The notification will be displayed at the start of the next workout until the battery in the handle is completely depleted causing the buttons on the handle to no longer function. The battery must be replaced to regain function of the buttons on the handle.

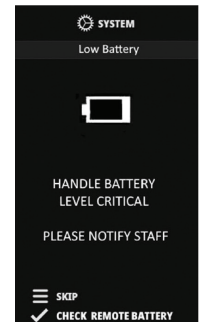

Handle Battery Replacement

The handle requires a standard 2032 coin battery which should be purchased locally.

1.
 - 1.1 Flip the handle over to reveal four screws on the underside of the handle.
 - 1.2 Remove screws with a 3mm Hex Key.

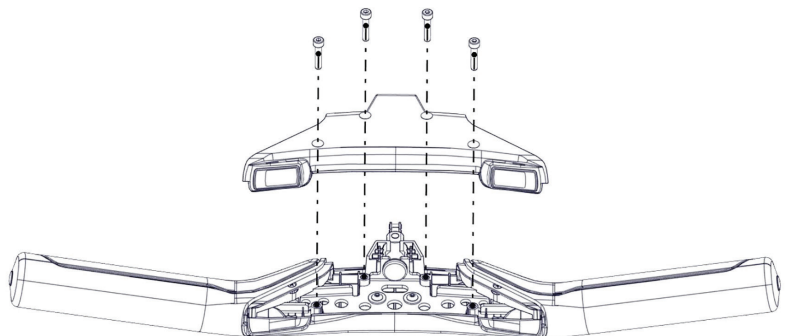

WARNING!

DO NOT ATTEMPT TO PRY THE BATTERY FROM THE FRONT OF THE BRACKET!!

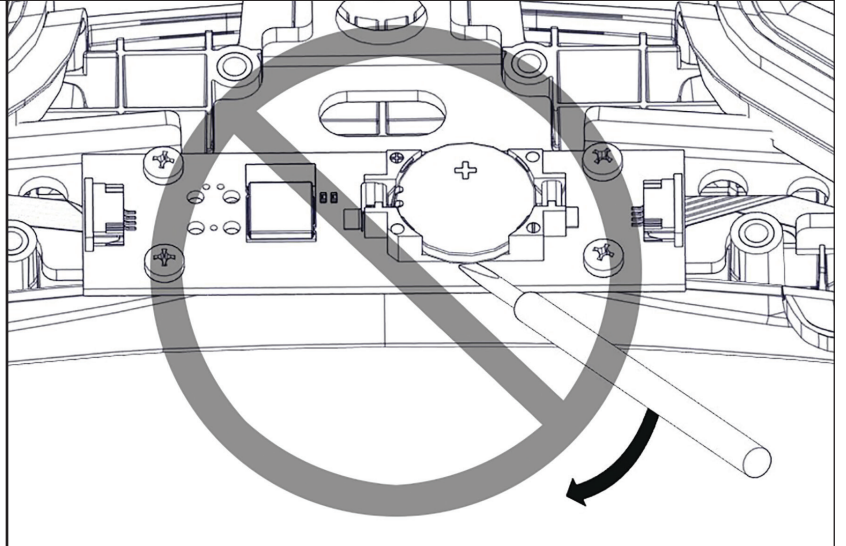

2.

2.1 Pry the battery out of its bracket with a small flat head screwdriver from the side of the bracket.

Dispose of the battery according to your local laws.

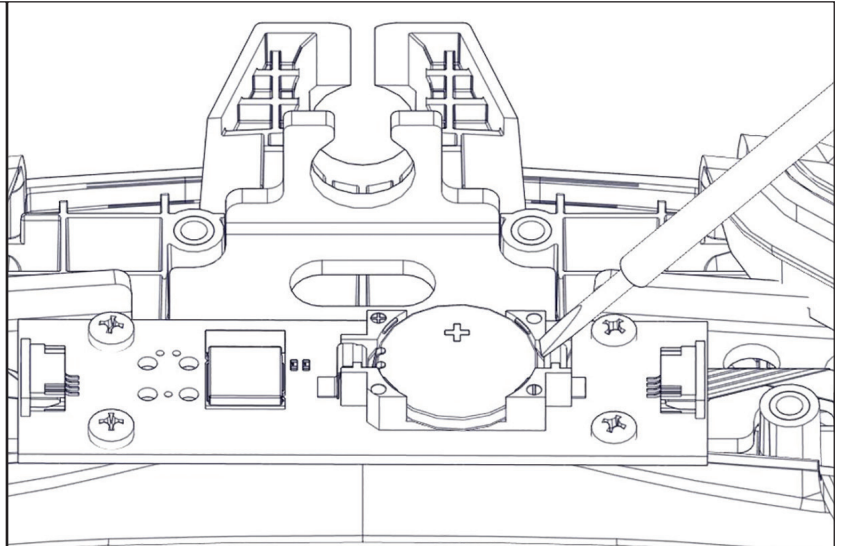

3.

Replacement Battery
1 pcs. 2032 Coin Battery

3.1 With the flat side up (+), position the edge of the new battery under the prongs (fig. 1).

Carefully push the battery down on the opposite side of the battery until it is secured into position (fig. 2).

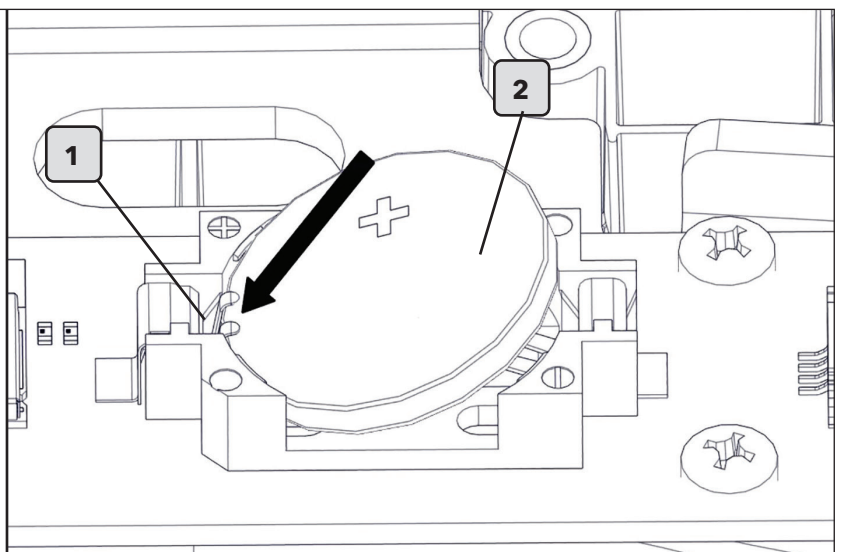

Test New Handle Battery

After the new battery has been inserted, the battery charge will be indicated by an LED (fig1) on the PCB by pressing either button on the handle (fig 1 & 2)

Please note: a fully charged battery will only be displayed for the first 20 button presses to save energy.

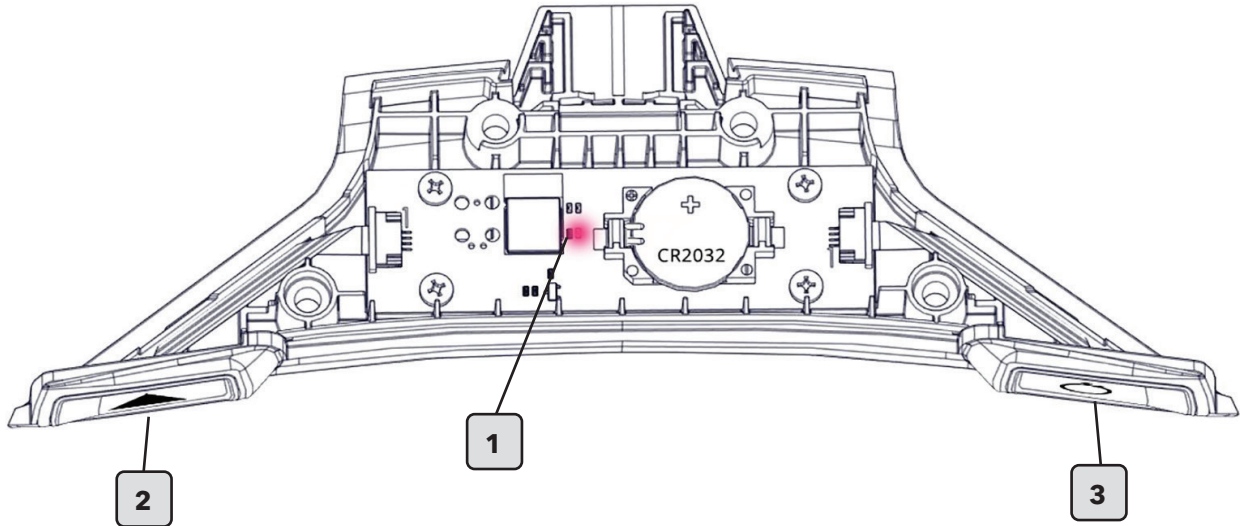

LED	DESCRIPTION
Lights up	Battery is full
Blinks	Battery is empty and must be replaced
No light	Battery is depleted. Battery is good but the button has been pushed more than 20 times.

When possible, please use rechargeable batteries to help save the environment.

Warning: If rechargeable batteries are in use, they must be removed from the handle for recharging. The charged battery must deliver 3 V output.

Warning: Do not attempt to recharge non rechargeable batteries.

Warning: Never use batteries other than C2032 Coin batteries in the handle.

Warning: Do not use different battery types or depleted and new batteries together.

Warning: Always insert the batteries with the correct polarity.

Warning: Never short circuit the connection terminals

Warning: Remove depleted batteries and dispose them correctly. Please follow the applicable laws or guidelines on disposal of batteries in your local area and adhere to them.

Binding/Footplate

Adjusting the foot binding

The slider footplate is designed to fit a wide range of foot sizes and is very simple to use. To adjust, lift the top sliding portion of the footplate and slide up or down. The numbers 1-8 marked on the footplate, represent a guideline from which the proper length can be determined. Secure the plate onto the mounting pegs and push down firmly to lock into position. Tighten the binding by pushing down on the tab. To release the binding, pull the tab.

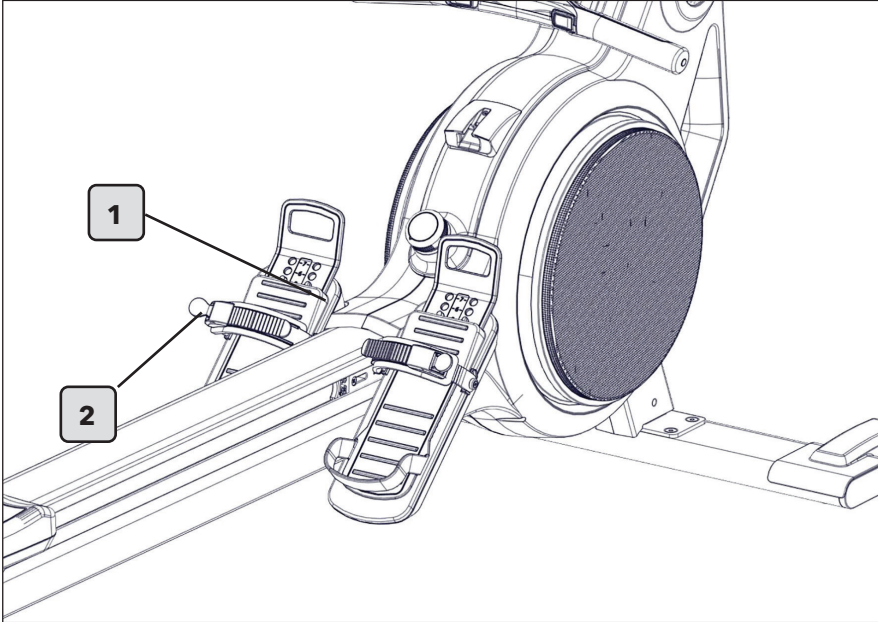

ITEM	DESCRIPTION
1	Slider Footplate
2	Binding - Tab

Resistance Knob



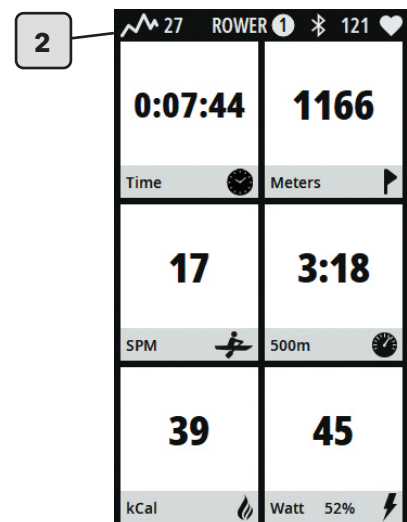
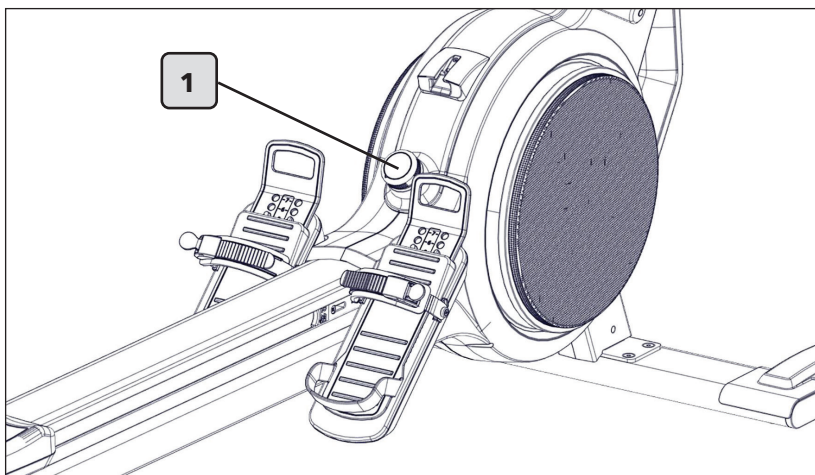

A knob is used to adjust the resistance from the lightest resistance to the heaviest from 1 - 100. The resistance value is displayed in the upper left-hand corner of the console screen once either a Quick Start, Power Training or Heart Rate Training workout is selected.



ITEM	DESCRIPTION
1	Resistance knob
2	Resistance as displayed during a workout

How to Row

1. Sit on the rower facing the console.
2. Position your feet in the foot bindings and fasten.
WARNING: An open binding could interfere with your workout.
3. Begin the stroke comfortably forward and push strongly back with your legs while keeping your arms and back straight.
4. Begin to pull your arms back as they pass over your knees and continue the stroke through to completion, rocking slightly back over your pelvis.
5. Return to the starting position and repeat.
6. For further details regarding rowing technique please refer to our website at www.lifefitness.com.

CATCH	DRIVE	FINISH	RECOVERY	CATCH
Comfortably forward with straight back and arms.	Push with the legs while arms remain straight.	Pull through with arms and legs rocking slightly back on your pelvis.	Upper body tips forward over your pelvis and move forward.	Catch and begin again.
				

After Your Workout.

1. Place the handle in it's fixture
2. Loosen the foot bindings and pull your feet out of the foot binding.
3. Close the binding after your workout.

Moving the Rower

We advise moving the rower with 2 people. Lift the rower from the back of the rail and onto the wheels on the stabilizer. Please take extra care when moving the rower over uneven surfaces. A second person is advisable to prevent the rower from tilting to one side. Allow a minimum safety distance away from any equipment, objects or walls.

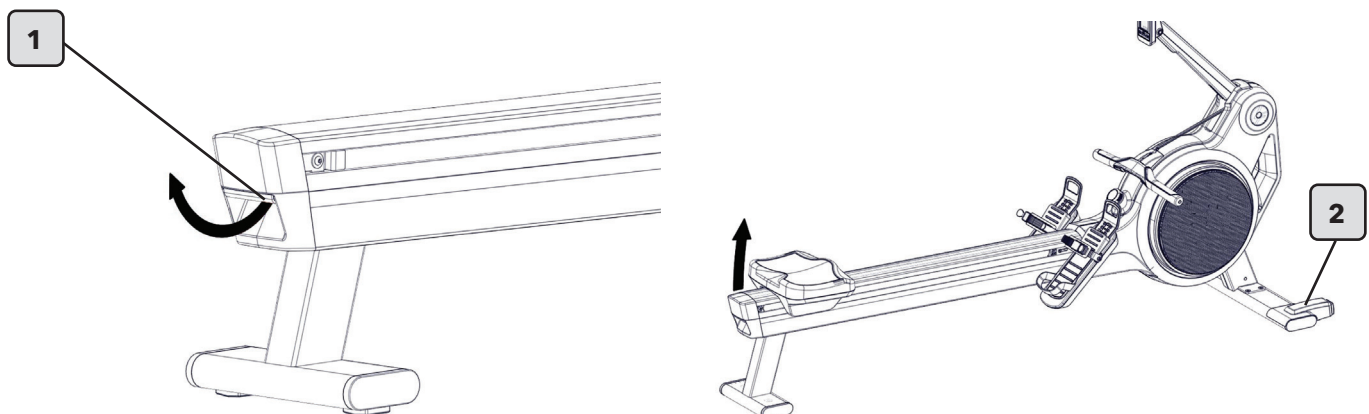

ITEM	DESCRIPTION
1	Transport Handle
2	Integrated wheels in Stabilizer

MAINTENANCE/SERVICE SCHEDULES

Please carefully observe the following instructions. The maintenance and care procedures must be performed as defined to ensure maximum operating safety and lifespan. Irregularly executed maintenance and care procedures will lead to increased wear to the product and will void the warranty. If you have any further questions on this topic, please contact our technical support.

Only use acid solvent-free and abrasive free maintenance care agents and cleaning agents to prevent damage to components of the rower.

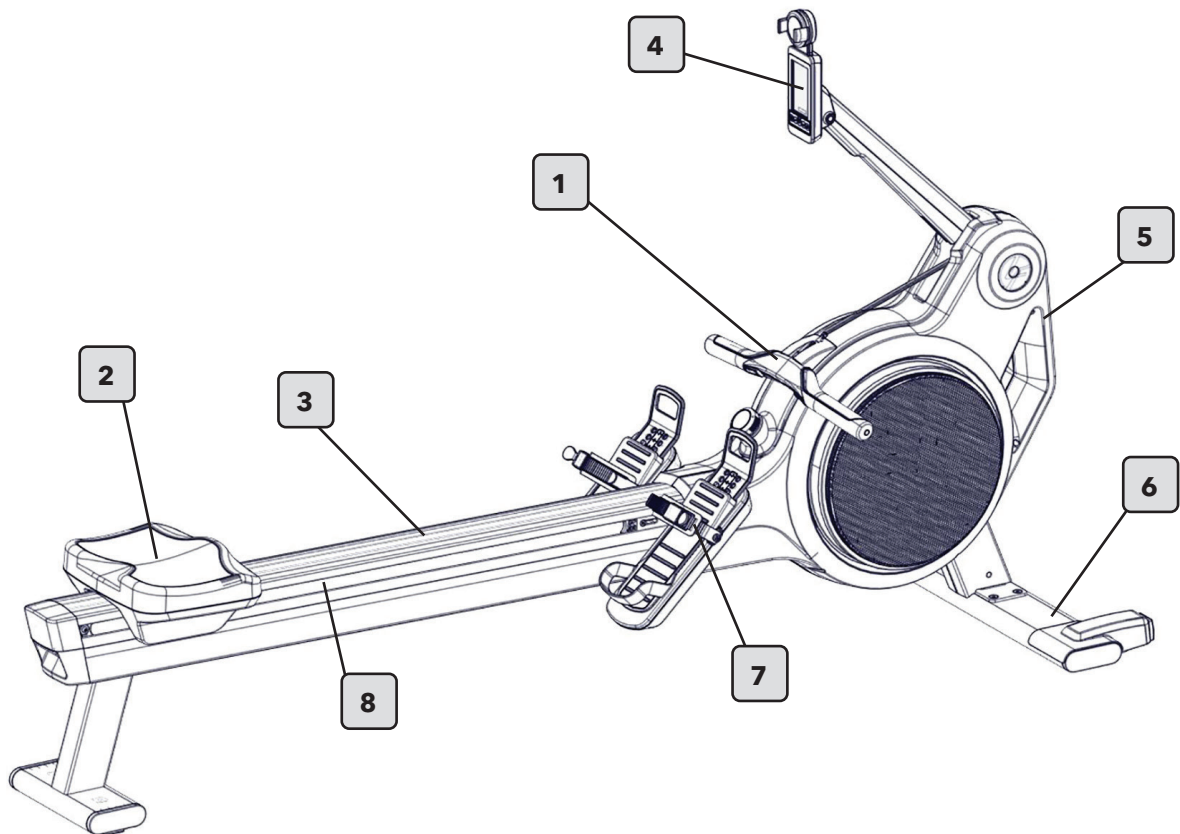

DAILY MAINTENANCE			
Item	Description	Instructions	Notes
1	Clean handle (1)	Clean with a lint free cloth and mild detergent / disinfectant after each workout.	
2	Clean seat (2)		
3	Clean rail (3)		
WEEKLY MAINTENANCE			
4	Clean console and arm (4)	Clean with a lint free cloth and mild detergent / disinfectant after each workout.	
5	Clean shroud (5)		
6	Clean stabilizers (6)		
7	Clean foot straps		
8	Clean castors / tracks (7)	Perform a visual inspection of the castors and rails and clean with mild detergent and lint free cloth is needed.	
9	Rub down with Maintenance spray 3,5,6,7 & 8	Rub down components with a lint free cloth and maintenance spray	

MONTHLY MAINTENANCE

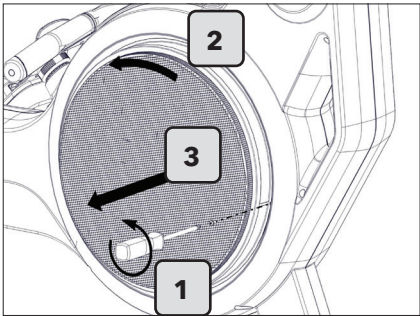
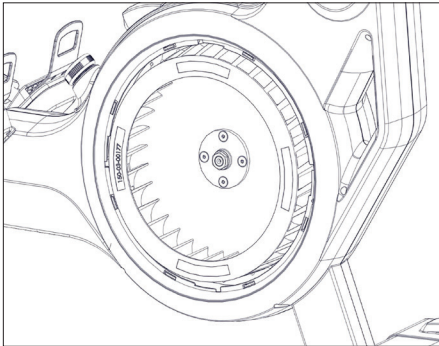
Item	Description	Instructions	Notes
10	Check complete rower for loose nuts or bolts.	Inspect the rower for loose nuts, bolts. Check that all connections are fitted firmly. Review the rower for damage and test function.	
11	<p>Vacuum dust from inside the right cover.</p> <ol style="list-style-type: none"> 1. Remove the screw 2. Turn the cover counter clockwise 3. Pull the cover from the rower. <ol style="list-style-type: none"> 4. Vacuum the dust from the right side of the rower 5. Reassemble. 	 	

MAINTENANCE EVERY 50 HRS OF USE

12	<p>Carefully extend the handle and chain from the rower. Run the chain from back to front through a dry lint free cloth, to clean the chain.</p> <p>Lubricate the chain by applying a fine, non-resinous oil to a cloth and running the chain through it from back to front.</p>		
----	--	---	--

WARRANTY

What is Covered

This LIFE FITNESS commercial exercise equipment product is warranted to be free of all defects in material and workmanship.

Who is Covered

The original purchaser or any person receiving the product as a gift from the original purchaser. Warranty will be voided on subsequent transfers.

How long it is covered

All coverage is provided by specific Product according to the guidelines listed in Warranty Information.

Who Pays Transportation and Insurance for Service

If the Product or any covered part must be returned to a service facility for repairs, We, Life Fitness, will pay all transportation and insurance charges for the first year. You are responsible for transportation and insurance charge after the first year.

What We Will Do To Correct Covered Defects

We will ship to you any new or rebuilt replacement part or component, or at our option, replace the Product. Such replacement parts are warranted for the remaining portion of the original warranty period.

What is Not Covered

Any failures or damage caused by unauthorized service, misuse, accident, negligence, improper assembly or installation, debris resulting from any construction activities in the Product's environment, rust or corrosion as a result of the Product's location, alterations or modifications without our written authorization or by failure on your part to use, operate and maintain the Product as set out in your Operation Manual ("Manual").

All terms of this warranty are void if this product is moved beyond the continental borders of the United States of America (excluding Alaska, Hawaii and Canada) and are then subject to the terms provided by that country's local authorized Life Fitness representative.

What You Must Do

Retain proof of purchase. use, operate and maintain the Product as specified in the Manual; notify the place of purchase of any defect within 10 days after discovery of the defect; if instructed, return any defective part for replacement or, if necessary, the entire Product for repair. Life Fitness reserves the right to decide whether or not a product is to be returned for repair.

How to Get Parts and Service

Refer to the Corporate Headquarters section of this manual for your local service contact information. Reference your name, address and the serial number of your Product (consoles and frames may have different serial numbers). They will tell you how to get a replacement part, or, if necessary, arrange for service where your Product is located.

Exclusive Warranty

THIS LIMITED WARRANTY IS IN LIEU OF ALL OTHER WARRANTIES OF ANY KIND EITHER EXPRESSED OR IMPLIED, INCLUDING BUT NOT LIMITED TO THE IMPLIED WARRANTIES OF MERCHANTABILITY AND FITNESS FOR A PARTICULAR PURPOSE, AND ALL OTHER OBLIGATIONS OR LIABILITIES ON OUR PART. We neither assume nor authorize any person to assure for us any other obligation or liability concerning the sale of this Product. Under no circumstances shall we be liable under this warranty, or otherwise, of any damage to any person or property, including any lost profits or lost savings, for any special, indirect, secondary, incidental or consequential damages of any nature arising out of the use of or inability to use this Product. Some states do not allow the exclusion or limitation of implied warranties or of liability for incidental or consequential damages, so the above limitations or exclusions may not apply to you.

Changes in Warranty Not Authorized

No one is authorized to change, modify or extend the terms of this limited warranty.

Effects of State Laws

This warranty gives you specific legal rights, and you may have other rights which vary from state to state and country by country.

Our Pledge To You

Our Products are designed and manufactured to the highest standards. We want you to be completely satisfied with our Products and will do everything possible under the terms of this warranty to keep you secure in knowing you have bought the best!

Warranty Information

HEAT PERFORMANCE ROW	
Frame	3 Years (excludes coatings)
Mechanical	2 Years
Electrical	1 Year
Wear Items	6 Months
Labor	90 Days
Mechanical includes: Resistance System, Handlebar (excludes electronics), Chain, Drivetrain	
Electronic includes: Console, Pcb's, Cable Harness, Batteries	
Wear items include: Seat and Foot Strap	

